

Manuscript submitted to Evolutionary Psychology

www.epjournal.net – 20xx. x: 1-15

Original Article

Showing Off in Humans: Male Generosity as a Mating Signal

Wendy Iredale, Department of Psychology, University of Kent, United Kingdom, wi4@kent.ac.uk

Mark Van Vugt, Department of Psychology, University of Kent, United Kingdom

Robin Dunbar, Institute of Cognitive and Evolutionary Anthropology, University of Oxford, United Kingdom

Abstract: We examined people's charity contributions while in the presence of an observer of the same sex, opposite sex, or no observer. Inspired by costly signaling theory, we hypothesized that men would be more generous in the presence of a potential mate. Men and women played a number of experimental games in which they could earn money. On completion of these games participants were asked what percentage of their earned money they would be willing to donate to charity. Our results show that men contribute more to charity when observed by a member of the opposite sex than by a member of the same sex or no observer. Conversely, female charity donations did not significantly vary across the three observer conditions. Findings support the notion that men's generosity might have evolved as a mating signal.

Keywords. Altruism, Generosity, Mate Preferences, Costly Signaling, Sex differences

Introduction

There are important sex differences in human generosity. Whereas women's helping is more often directed towards kin and friends, men are more generous in interactions with strangers, for instance, in bystander helping, acts of public charity, and public good provision (Eagly and Crowley, 1986; Hawkes, 1993; Johnson, 1996; Latané, 1970). Men's generosity is difficult to explain with traditional evolutionary theories such as kin selection and reciprocal altruism (Fehr and Fishbacher, 2003; Hamilton, 1964; Trivers, 1971). Here we investigate the possibility that men's generosity serves as a signal to attract mates.

This hypothesis stems from an integration of costly signaling and sexual selection theory (Darwin, 1871; Zahavi and Zahavi, 1997). Costly signaling theory suggests that particular traits evolve because they convey useful information to others about an individual's qualities; the costlier the trait, the more reliable the signal-- hence these traits are labeled as "handicaps" (Grafen, 1990). An example of a handicap might be public generosity as it provides important information to others about the individual's quality.

Sexual selection theory suggests that human males and females might differ in what signals they pay attention to (Buss and Schmitt, 1993; Miller, 2000; cf. Darwin, 1871). Due to evolved differences in parental investment (Bateman, 1948), men place more emphasis on fertility cues in choosing sexual mates (e.g., youthfulness, physical attractiveness), whereas women place a stronger emphasis on cues indicating the likely provision of

SHOWING OFF

resources and relationship commitment (Buss, 1989; Kenrick and Keefe, 1992). If women are relatively more concerned about these cues, this, in turn, selects for traits in men that convey these qualities to members of the opposite sex. Since females consider kindness and helpfulness important indicators of male attractiveness (Miller, 2007), we predict that men might strategically use a public display of generosity to show off their quality as a potential mate.

This show-off hypothesis of male generosity is consistent with field data. For instance, among hunter-gatherer societies, men who regularly provide large animal meat have more sexual partners (Hawkes, 1993; Hawkes and Bliege Bird, 2002). It has been suggested, that in restaurants, groups of men leave much better tips for waitresses than groups of women, and men on dates with women leave especially good tips (Miller, 2000). When in the presence of a female, men also donate more money to panhandlers (Goldberg, 1995), and act heroically to help strangers in emergencies (Griskevicius et al., 2007; Latané, 1970). Finally, recent data from wild chimpanzee populations suggest that males use food-sharing to show-off to sexually receptive females (Hockings et al., 2007).

Currently, however, this hypothesis has not been tested with humans under carefully controlled experimental conditions. Hence, this research provides the first empirical demonstration of the show off hypothesis of men's generosity as a mate signal. Men and women were asked what percentage of earned money they would be willing to donate to charity whilst being observed by a confederate who is either a member of the same sex or opposite sex (we included a no observer condition as control). Our prediction is that compared to other conditions, only men will increase generosity when being

SHOWING OFF

observed by an (attractive) member of the opposite sex.

Materials and Methods

Participants and Design

Ninety students (45 female, 45 male) with a mean age of 22 years were recruited via the university research participation scheme at the University of Kent. Participants were tested independently in experimental cubicles, each containing a desk, chair and computer. A 2 (sex) x 3 (audience) between-subjects design was employed with participants randomly allocated to experimental conditions. The dependent variable, altruism, was measured through the percentage of earned money participants donated to charity. We tested whether charity donations would differ between the sexes under three different audience conditions: whilst being observed by a confederate who was either a member of the opposite sex or same sex as the participant (i.e., a no observer condition served as control). In the observer conditions, the confederate sat approximately three feet away from the participant in their cubicle where they could see both the participant and the computer screen, see figure 1.

SHOWING OFF

Figure 1. Example of observer-participant set-up in the experimental cubical.

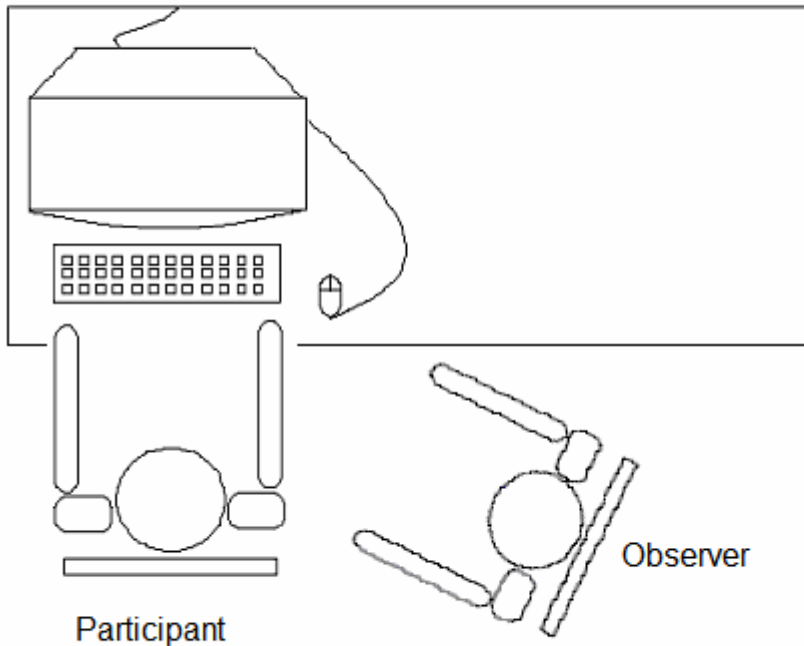

Observers

We recruited a male and female confederate to assist with the experiment. To examine if altruism is a mate signal we required our confederates to be considered as potential mates, therefore, we recruited two observers that were regarded as physically attractive. We advertised in the University of Kent's drama department for confederates to act as observers. Ten female and eight male Drama students replied and agreed to have their photograph taken and rated. On a scale from 1-6 (1 = not very attractive, 6 = very attractive), ten male students rated the female photographs and another ten female students the male photographs. We recruited the female ($M = 5.1$, $SD = 0.77$) and male actors ($M = 4.9$, $SD = 0.57$) with the highest mean attractiveness ratings for the experiment.

SHOWING OFF

Procedure

Participants arrived at the experiment individually. They were asked to enter the cubical (a closed room containing two chairs, a desk and a computer) and to take a seat at the computer. In the observer conditions, an observer was sitting in cubical as the participant entered and remained present throughout the experimental games and charity donation. The experimenter gave no explanation for the presence of the observer but stated that participants would be fully debriefed at the end of the study. Participants were asked not to interact with the observer; should they have any problems with the study they were asked to leave the cubical and find the experimenter. Once the participant was seated, the experimenter gave them the opportunity to ask any questions and checked that they were happy to continue. The experimenter then left the cubical and told the participant to follow on screen instructions at their own pace. On screen instructions explained to participants that they were about to play a number of experimental games in which they could earn up to £24 (approximately \$48). Although financial constraints meant that only six participants could receive the money earned throughout the experiment, participants were aware that the money they were playing with was real, that they could be one of the six people chosen at random and therefore the money they earned could be theirs.

On completion of these games participants were asked if they would like to donate a percentage of their earnings to charity. Since the money participants chose to donate was earned rather than given to them free by the experimenter, any donations to charity were considered costly. To control for differences in earnings, financial totals were not revealed to participants prior to the charity question. As some charities could appeal to some people

SHOWING OFF

more strongly than others, the charity's name, NSPCC (National Society for the Prevention of Cruelty to Children; a UK child charity), was only revealed after they made a donation.

After making their donation, in the observer conditions the on screen computer instructions told the observer to leave the room. Participants were then asked several questions in private. In observer conditions questions included rating the sexual attractiveness of their observer and their self-rated attractiveness on a scale from 1-7 (1 = not attractive at all; 7 = extremely attractive). In addition, participants were asked to state their sexual orientation. Finally, they were debriefed and dismissed. At the end of the study six people selected at random received the money that they earned throughout the experimental games minus the charity donation; these charity donations were given to the NSPCC.

Results

To test our hypothesis we compared the sex differences in charity contributions between the opposite sex condition, the same sex condition and no observer condition. Because our hypothesis concerned altruism as heterosexual mate signal, participants who indicated themselves to be homosexual ($N = 5$) were excluded from further data analyses.

Both males and females rated their opposite sex observer as highly attractive. On a scale from 1-7 (1 = not attractive at all; 7 = extremely attractive), males gave the opposite sex observer (female) a mean attractive rating of 5.13 ($SD = 1.13$), whereas females gave the male observer a mean attractive rating of 4.66 ($SD = 1.11$).

As predicted, we found that only men significantly differed in their charity

SHOWING OFF

contribution across the three audience conditions $F(2, 42) = 4.60, p = .01, \eta^2 = .18$. Men contributed considerably more in the opposite sex condition ($M = 57.00, SD = 28.83$) than the no observer condition ($M = 34.00, SD = 24.51$), $F(1, 28) = 5.54, p = .03, \eta^2 = .17$ and same sex condition ($M = 28.67, SD = 28.06$) $F(1, 28) = 7.44, p < 0.01 (p = .01), \eta^2 = .21$. The same sex and no observer conditions did not differ from each other for men, $F(1, 28) = 0.31, p = .58, \eta^2 = .01$.

Conversely, female contributions did not significantly vary across the three audience conditions $F(2, 42) = .03, p = .97, \eta^2 = .00$. Females did not significantly donate more in the opposite sex condition ($M = 38.67, SD = 27.42$) and the no observer condition ($M = 41.33, SD = 31.76$), $F(1, 28) = .06, p = .81, \eta^2 = .00$ or the same sex condition ($M = 40.00, SD = 26.86$), $F(1, 28) = 0.02, p = .89, \eta^2 = .00$. No significant difference between the same sex and no observer conditions was found $F(1, 28) = .02, p = .90, \eta^2 = .01$.

To confirm this, a comparison of male and female donations shows that males were more generous than females in the presence of an opposite sex observer (Males $M = 57.00, SD = 28.83$ vs Females $M = 38.67, SD = 27.42$), $F(1, 28) = 3.18, p = 0.09, \eta^2 = .10$; however, male and female donations did not significantly differ in the same sex (Males: $M = 28.67, SD = 28.06$ vs Females: $M = 40.00, SD = 26.86$), $F(1, 28) = 1.23, p = 0.27, \eta^2 = .04$ and no observer conditions (Males: $M = 34.00, SD = 24.51$ vs Females: $M = 41.33, SD = 31.76$), $F(1, 28) = 0.50, p = 0.49, \eta^2 = .02$. The means are displayed in Figure 2.

SHOWING OFF

Figure 2. Comparing males and females donations to charity across the three observer conditions

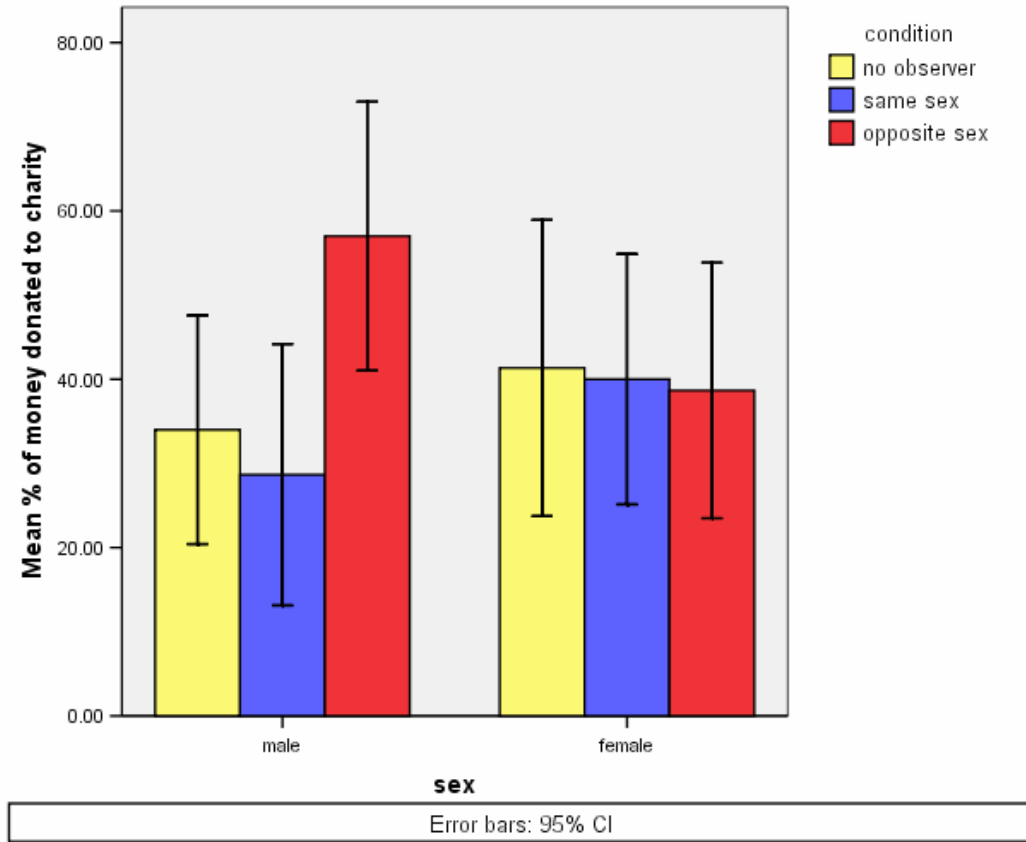

Are these generous activities influenced by perceptions of sexual attractiveness? As expected, we found a positive correlation between generosity and the perceived sexual attractiveness of the observer (1 = not attractive at all; 7 = extremely attractive) in the opposite sex condition and, importantly, only for male participants, $r(15) = .46, p < .05$, not for females, $r(15) = .03, p = .46$. In addition, we found a relationship between self-rated attractiveness and donation to charity for both men and women in the opposite sex condition. Men and women who self-rated their own attractiveness as average or lower

SHOWING OFF

(four or less on a rating scale from 1-7; 1 = not attractive at all; 7 = extremely attractive) were considerably more generous than those who rated their own attractiveness as high (Men: 68.3% vs. 57.2%; Women: 58.0% vs. 38.7%). Unfortunately, the numbers per condition were too small to conduct any meaningful statistical tests.

Discussion

To our knowledge, this is the first experimental demonstration of the show off hypothesis for men's generosity. Whereas female generosity was not influenced by the sex or presence of an observer, male generosity was. Men acted more generously in the presence of an attractive member of the opposite sex than in the presence of a same sex observer or no observer. In the opposite sex condition men donated over half (57%) of the earnings to charity. We interpret this as evidence that men's generosity may be a mating tactic. This interpretation is consistent with many observed sex differences in human generosity.

Whereas women are more helpful in caring and nurturing situations, men engage in more conspicuous helping acts, such as hunting, bystander helping, group defense, and public philanthropy (Hawkes, 1993; Kelly and Dunbar, 2001; Latané, 1970; Van Vugt et al., 2007). Generally, the greater the costs and the larger the third-party benefits, the larger the potential audience for these signals (Bliege Bird and Smith, 2005).

What exactly does male generosity signal? The literature has put forward two rival hypotheses (Kelly and Dunbar, 2001; Miller, 2000). The good gene hypothesis suggests that men's generosity signals their underlying genetic qualities, whereas the caring hypothesis suggests the willingness to share resources. Our findings suggest that men who

SHOWING OFF

consider themselves physically less attractive are more generous. Perhaps, then, generosity is a mating strategy for men who cannot offer traits signaling good gene quality such as physical attractiveness or bodily symmetry (Gangestad and Simpson, 2000; Waynforth and Dunbar, 1995). That the same effect was also found for women suggests that more research is needed to explain the relationship between own attractiveness and altruism in potential mate situations.

We should note a potential limitation of the experiment. Generosity was displayed through monetary contributions only and this was deemed suitable for a student sample for which money is a scarce resource. But do our findings generalize to other populations and other acts of helping? We think they do. Across human societies, very public acts of generosity, such as philanthropy, bystander intervention, and heroism at war, are primarily male activities (Miller, 2000; Van Vugt et al., 2007). Anthropological studies have found numerous examples of male generosity to impress females such as big game hunting and feasting and there is some evidence that such displays increase male reproductive success (Bliege Bird & Smith, 2005; Chagnon, 1997; Hawkes, 1993).

This experiment suggests that men may show off altruism as part of a mating strategy. It remains to be seen if and when women find altruistic men sexually more attractive.

References

Bateman, A. J. (1948). Intrasexual selection in *Drosophila*. *Heredity*, 2, 349-368.

SHOWING OFF

- Bliege Bird, R., and Smith, E. A. (2005). Signaling theory, strategic interaction, and symbolic capital. *Current Anthropology*, 46, 221-248.
- Buss, D. M. (1989). Sex differences in human mate preferences: Evolutionary hypotheses tested in 37 cultures. *Behavioral and Brain Sciences*, 12, 1-49.
- Buss, D. M., and Schmitt, D. P. (1993). Sexual strategies theory: An evolutionary perspective on human dating. *Psychological Review*, 100, 204-232.
- Chagnon, N. A. (1997). *Yanomamö. Fifth addition*. Fort Worth: Harcourt Brace.
- Darwin, C. (1871). *The Descent of Man and Selection in Relation to Sex*. London: John Murry.
- Eagly, A. H., and Crowley, M. (1986). Gender and helping behavior: A meta-analytic review of the social psychological literature. *Psychological Bulletin*, 100, 283.
- Fehr, E., and Fischbacher, U. (2003). The nature of human altruism. *Nature*, 425, 785-791.
- Gangestad, S. W., and Simpson, J. A. (2000). The evolution of human mating: Trade-offs and strategic pluralism. *Behavioral and Brain Sciences*, 23, 573-587.

SHOWING OFF

Goldberg, T. L. (1995). Altruism towards panhandlers: Who gives? *Human Nature*, 6, 79-89.

Grafen, A. (1990). Biological signals as handicaps. *Journal of Theoretical Biology*, 144, 517-546.

Griskevicius, V., Tybur, J. M., Sundie, J. M., Cialdini, R. B., Miller, G. F. and Kenrick, D. T., et al. (2007). Blatant Benevolence and Conspicuous Consumption: When Romantic Motives Elicit Strategic Costly Signals. *Journal of Personality and Social Psychology*, 93, 85-102.

Hamilton, W. D. (1964). The genetic evolution of social behavior I and II. *Journal of Theoretical Biology*, 7, 1-52.

Hawkes, K. (1993). Why hunter-gatherers work: An ancient version of the problem of public goods. *Current Anthropology*, 34, 341-361.

Hawkes, K., and Bliege Bird, R. (2002). Showing off, handicap signaling, and the evolution of men's work. *Evolutionary Anthropology*, 11, 58-67.

Hockings, K. J., Humle, T., Anderson, J. R., Biro, D., Sousa, C., Ohashi, G., and Matsuzawa, T. (2007) Chimpanzees Share Forbidden Fruit. *PLoS ONE* 2(9), e886 (DOI:10.1371/journal.pone.0000886)

SHOWING OFF

Johnson, R. C. (1996). Attributes of Carnegie medalists performing acts of heroism and of the recipients of these acts. *Ethology and Sociobiology*, 17, 355-362

Kelly, S., and Dunbar, R. I. M. (2001). Who dares wins: Heroism versus altruism in women's mate choice. *Human Nature*, 12, 89-105.

Kenrick, D. T., and Keefe, R. C. (1992) Age preferences in mates reflect sex differences in human reproductive strategies. *Behavioral and Brain Sciences*, 15, 75-133

Latané, B. (1970). Field studies of altruistic compliance. *Representative Research in Social Psychology*, 1, 49-61.

Miller, G. (2000). *The Mating Mind: How Sexual Choice Shaped the Evolution of Human Nature*. London: Heinemann.

Miller, G. F. (2007). Sexual selection for moral virtues. *Quarterly Review of Biology*, 82, 97-125.

Trivers, R. (1971). The evolution of reciprocal altruism: *Quarterly Review of Biology*, 46, 35-57.

SHOWING OFF

Van Vugt, M., De Cremer, D., and Janssen, D. (2007). Gender differences in cooperation and competition: The male warrior hypothesis. *Psychological Science, 18*, 19-23.

Waynforth, D., and Dunbar, R. I. M. (1995). Conditional mate choice strategies in humans: Evidence from 'Lonely Hearts' advertisements. *Behavior, 132*, 755-779.

Zahavi, A., and Zahavi, A. (1997). *The Handicap principle: a missing part of Darwin's puzzle*. Oxford: Oxford University Press.